

# Goldilocks and the Three Bears Fine Motor Skills Story

One day, Goldilocks went for a walk in the forest and found a house.

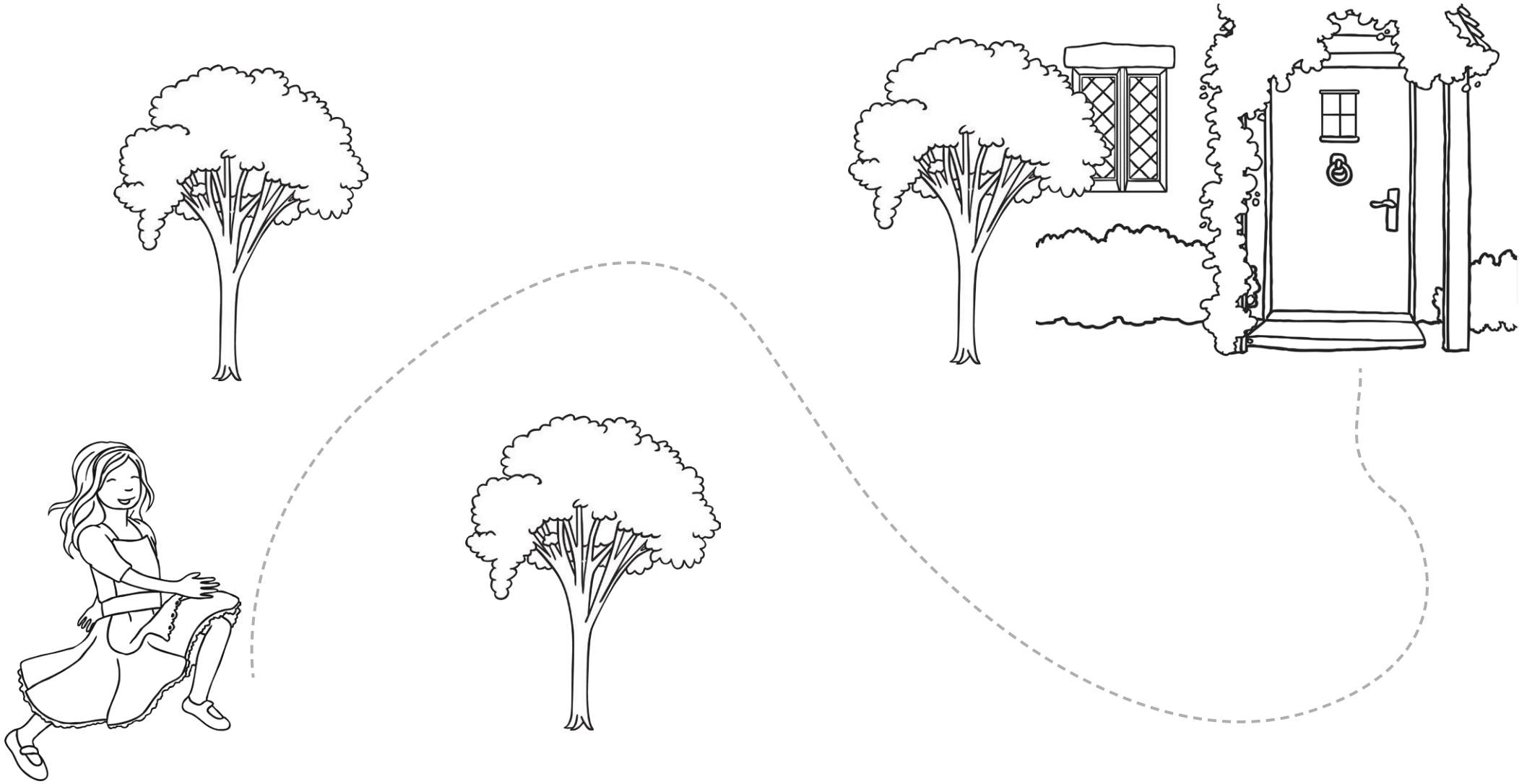

# Goldilocks and the Three Bears Fine Motor Skills Story

At the table, there were three bowls of porridge. Goldilocks was hungry so she tasted them all.

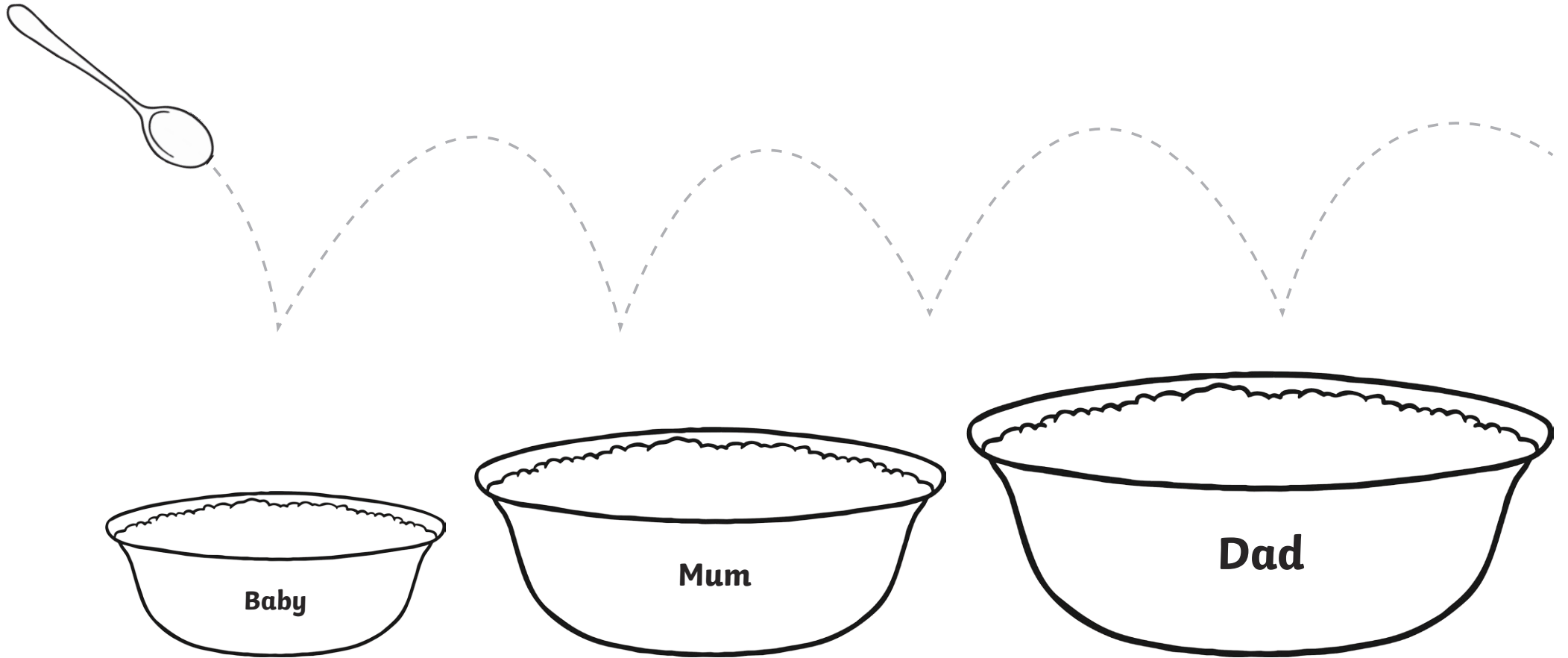

# Goldilocks and the Three Bears Fine Motor Skills Story

The big bowl of porridge was too salty. The medium bowl was too sweet. The small bowl tasted just right. So, she ate it up!



# Goldilocks and the Three Bears Fine Motor Skills Story

Goldilocks saw three chairs. She felt tired so she sat in them all.

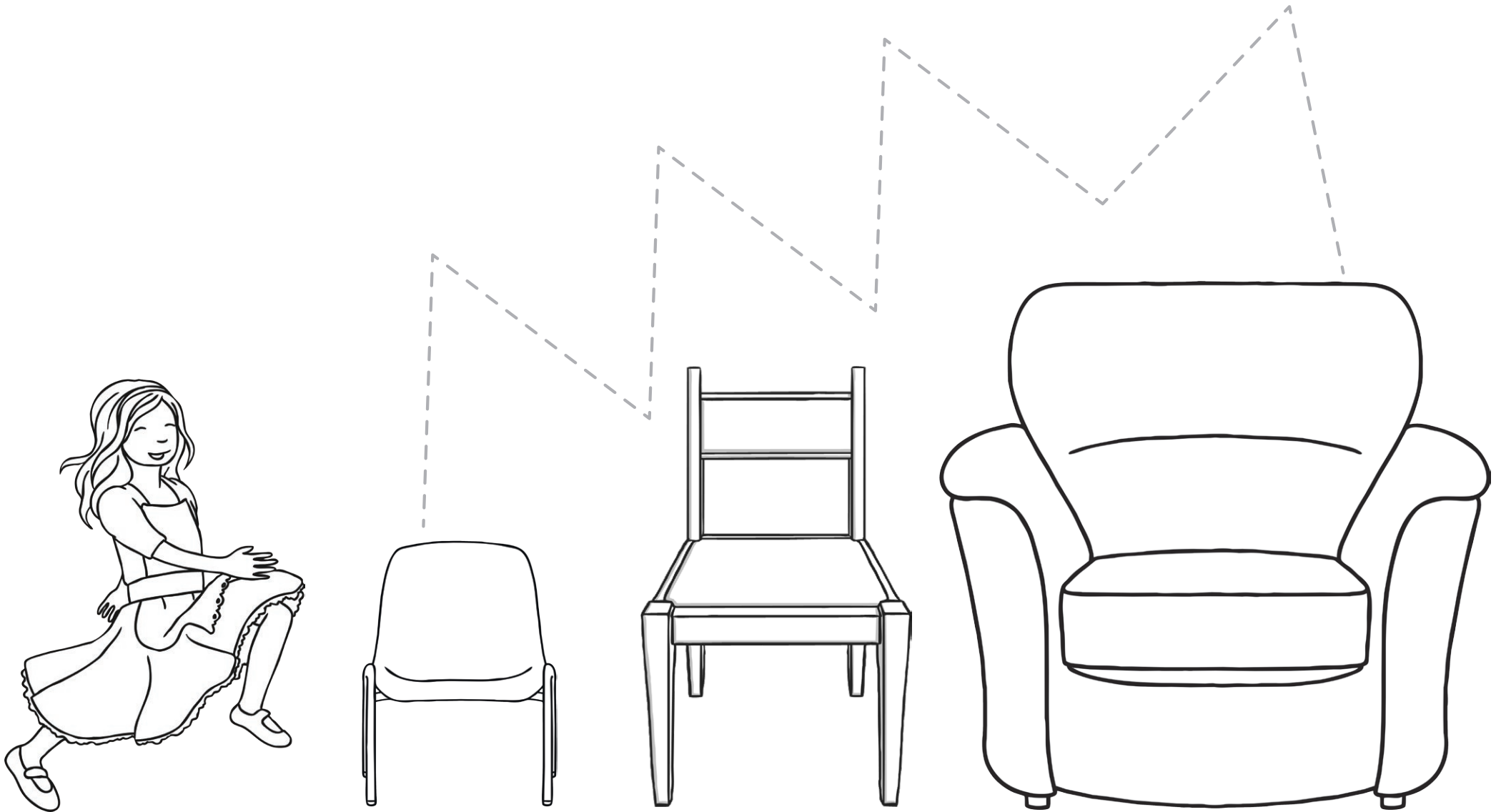

# Goldilocks and the Three Bears Fine Motor Skills Story

The big chair was too hard. The medium-sized chair was too soft. The small chair was just right.



# Goldilocks and the Three Bears Fine Motor Skills Story

Just as Goldilocks settled down into the chair to rest, it broke into pieces.

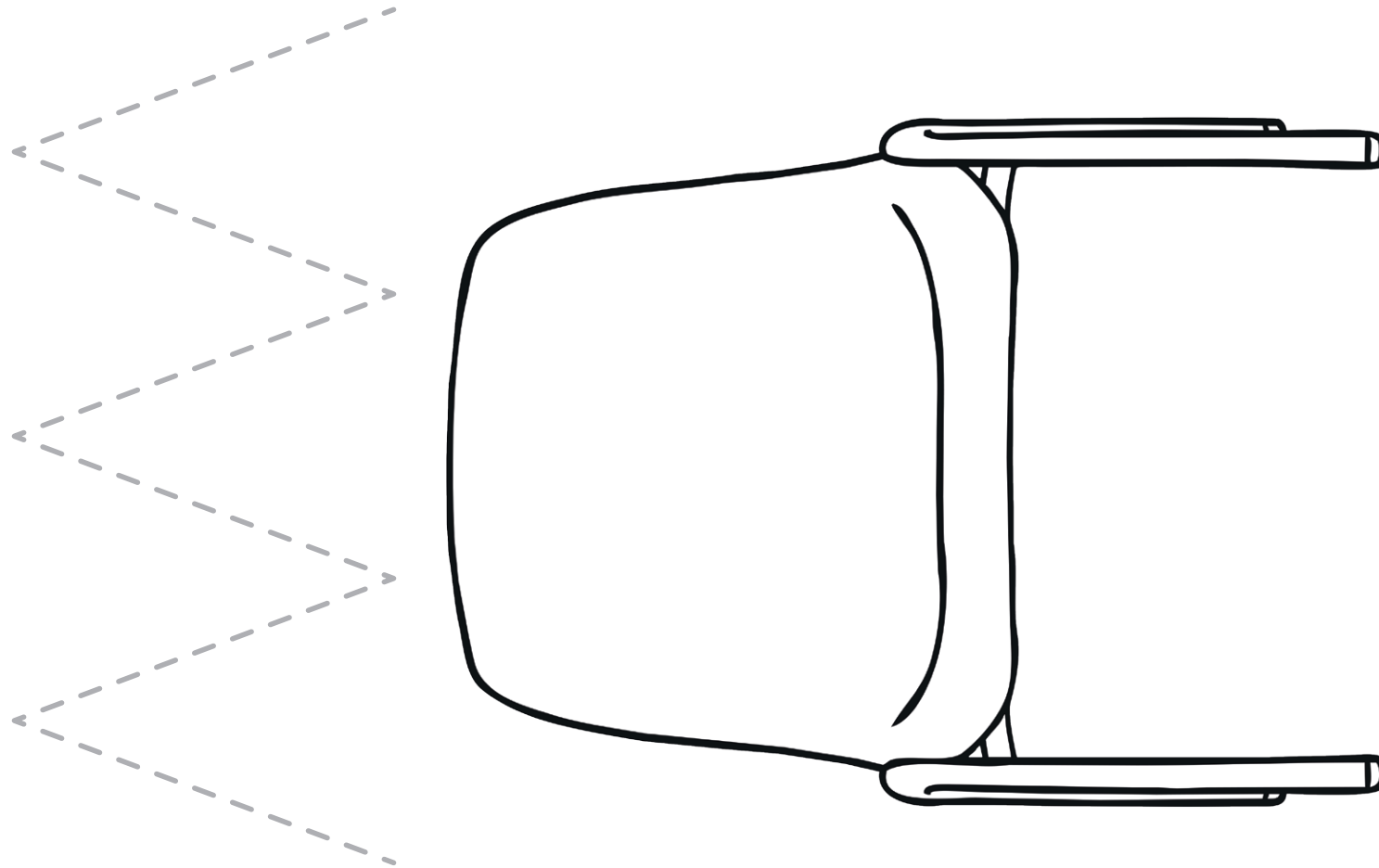

# Goldilocks and the Three Bears Fine Motor Skills Story

By now, Goldilocks was very tired so she went upstairs to the bedroom.

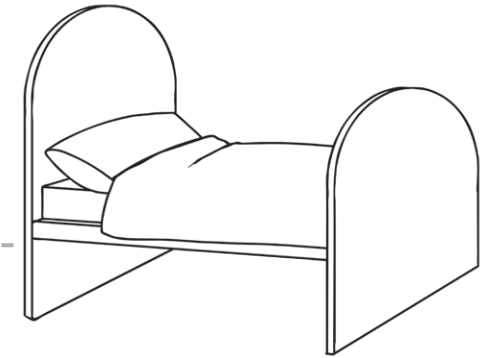
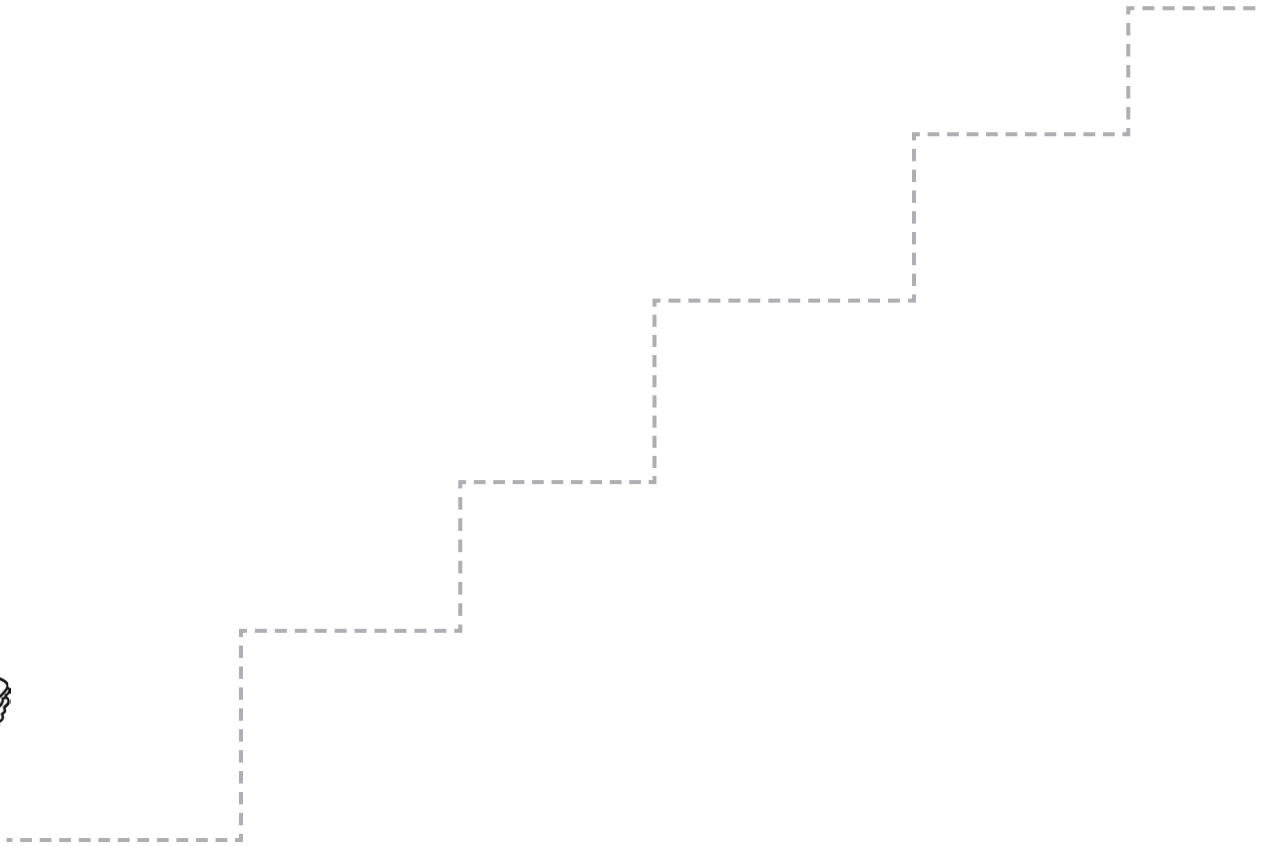

# Goldilocks and the Three Bears Fine Motor Skills Story

She lay down on the big bed. "This is too hard!" she said.

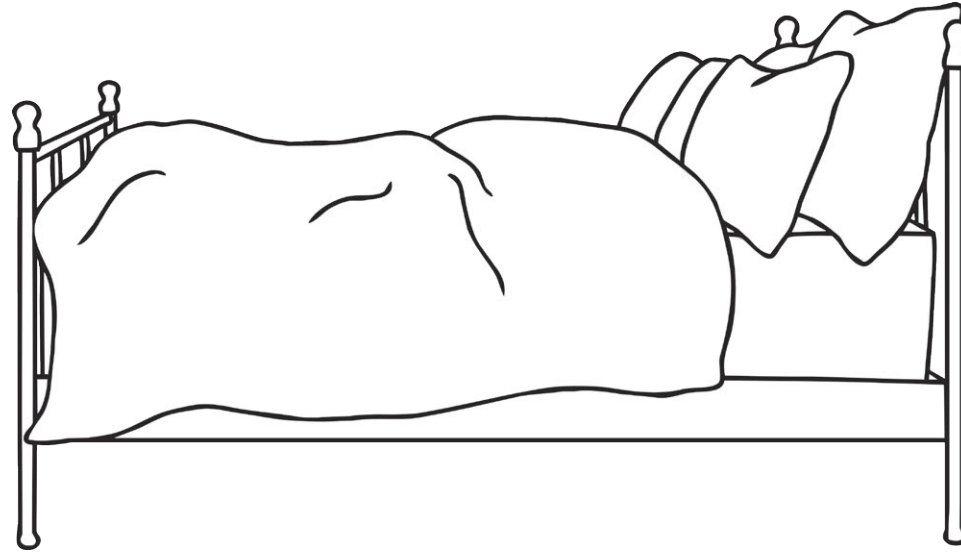

Four horizontal dashed lines for handwriting practice, spaced evenly down the page.



# Goldilocks and the Three Bears Fine Motor Skills Story

She lay down on the medium-sized bed. "This is too soft!" she said.

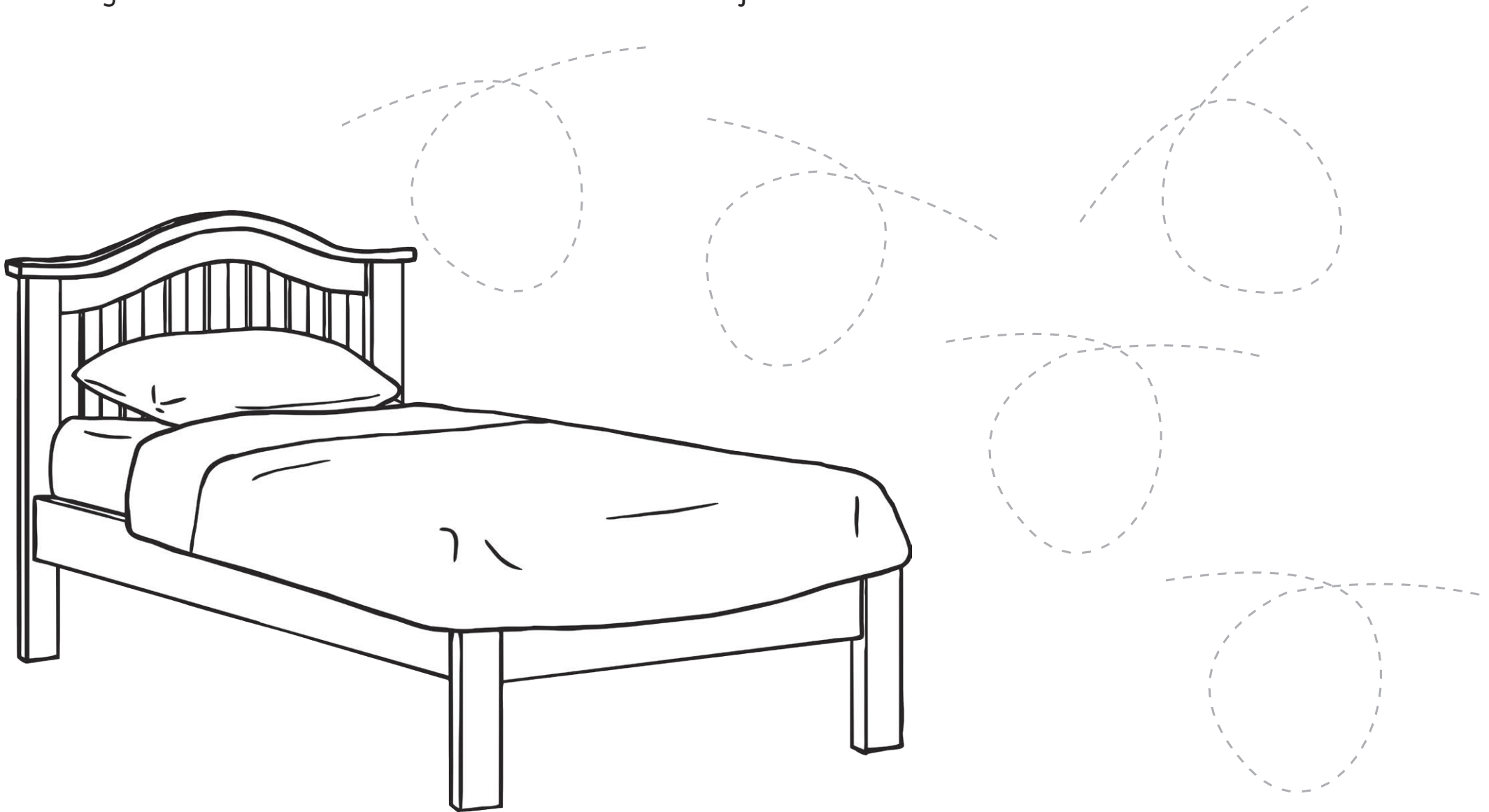

# Goldilocks and the Three Bears Fine Motor Skills Story

Then, she lay down on the small bed. "This is just right." she said and Goldilocks fell asleep.

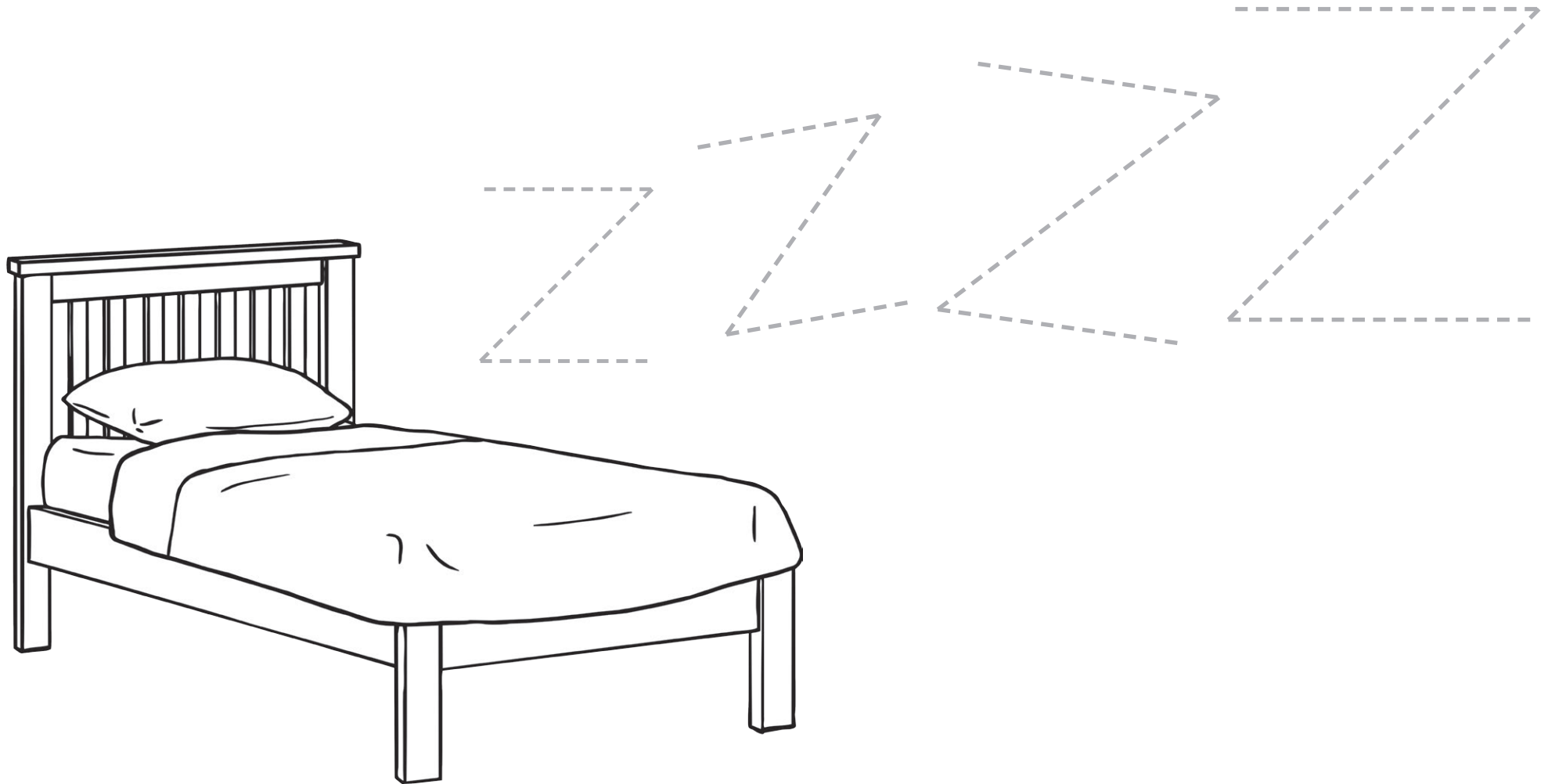

# Goldilocks and the Three Bears Fine Motor Skills Story

As she was sleeping the Three Bears came home.

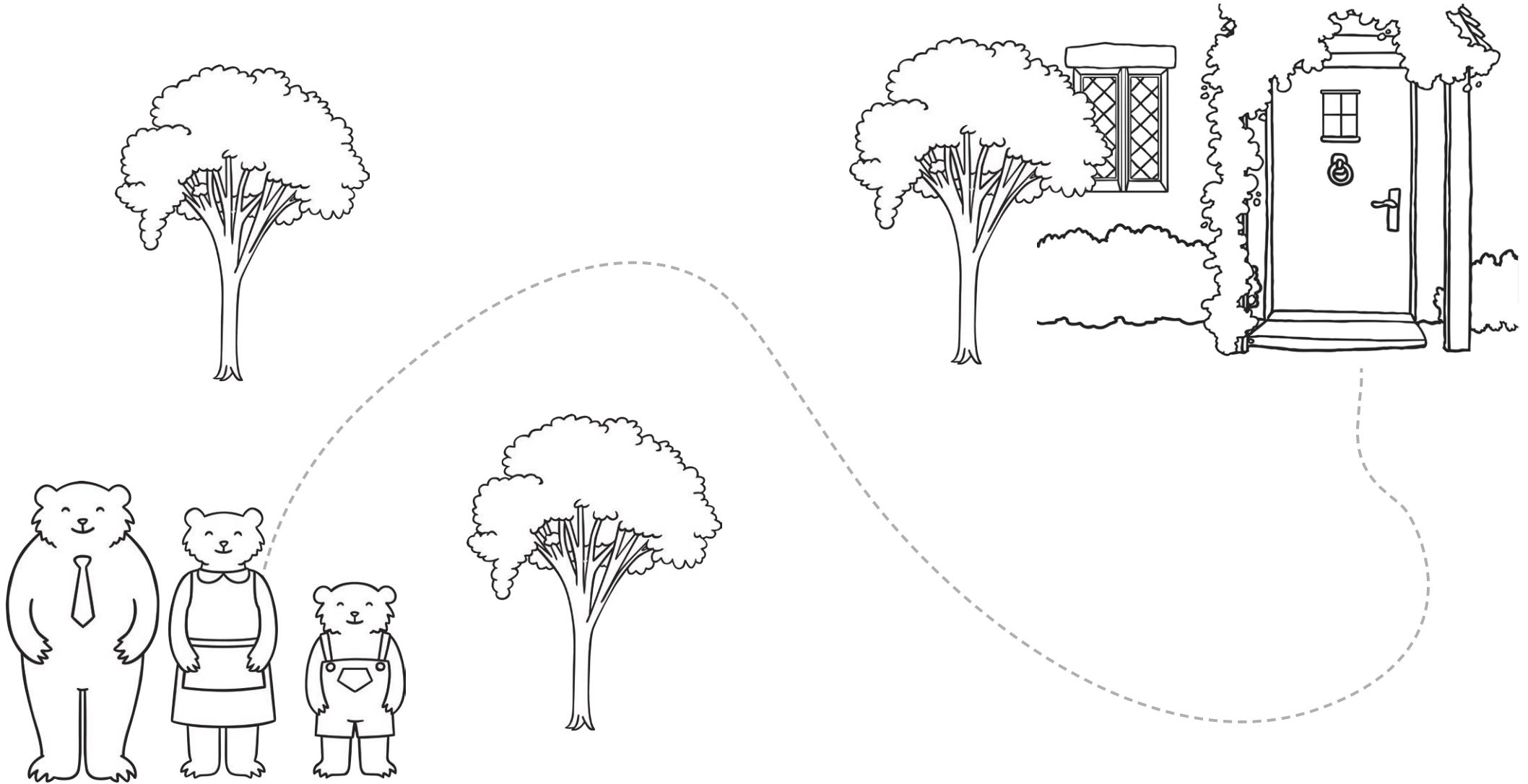

# Goldilocks and the Three Bears Fine Motor Skills Story

“Someone’s been eating my porridge!” growled Daddy Bear. “Someone’s been eating my porridge!” said Mummy Bear. “Someone’s been eating my porridge and it’s all gone!” said Baby Bear

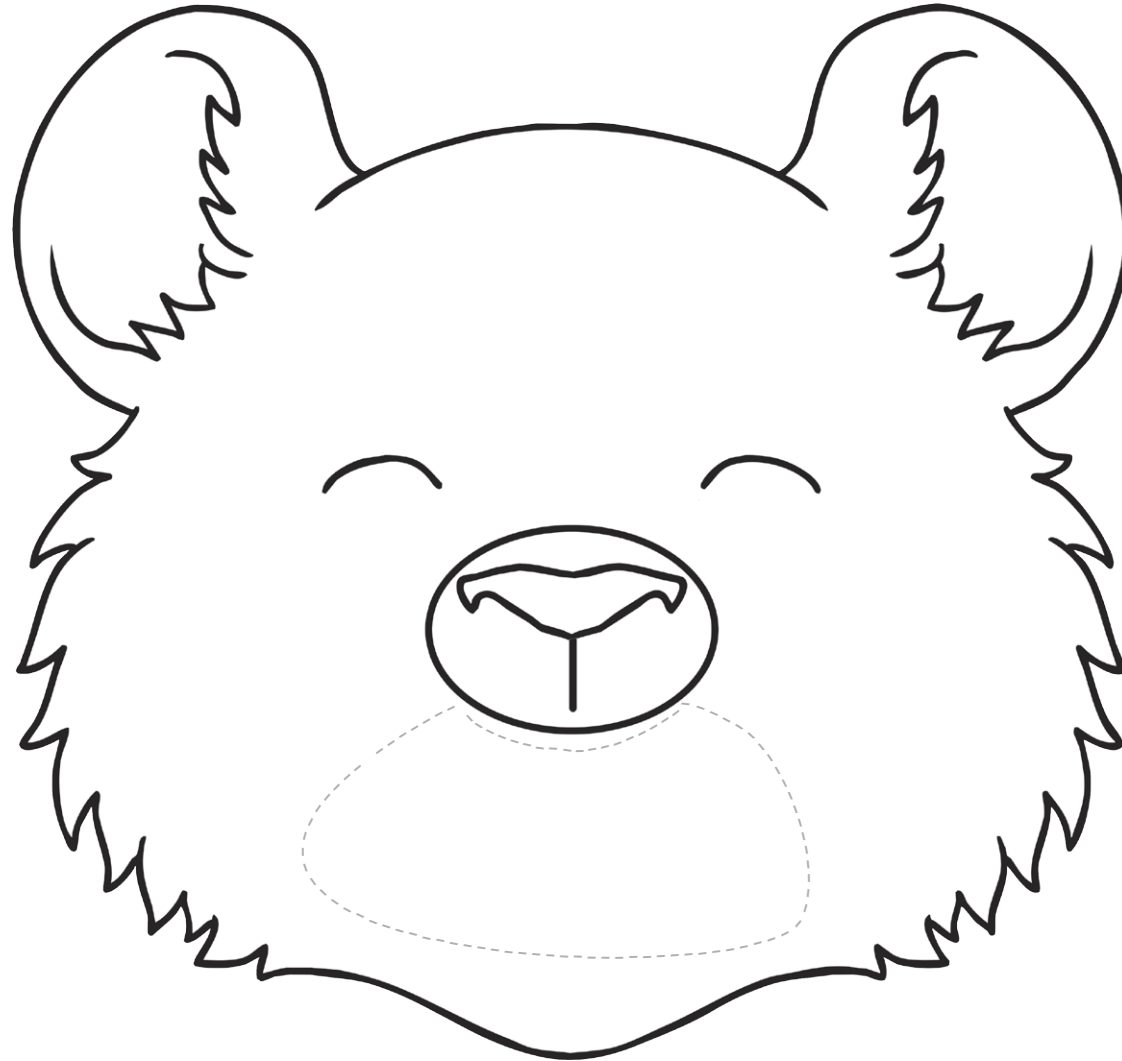

# Goldilocks and the Three Bears Fine Motor Skills Story

“Someone’s been sitting in my chair!” said Daddy Bear. “Someone’s been sitting in my chair!” said Mummy Bear. “Someone’s been sitting in my chair and it’s broken!” cried Baby Bear.

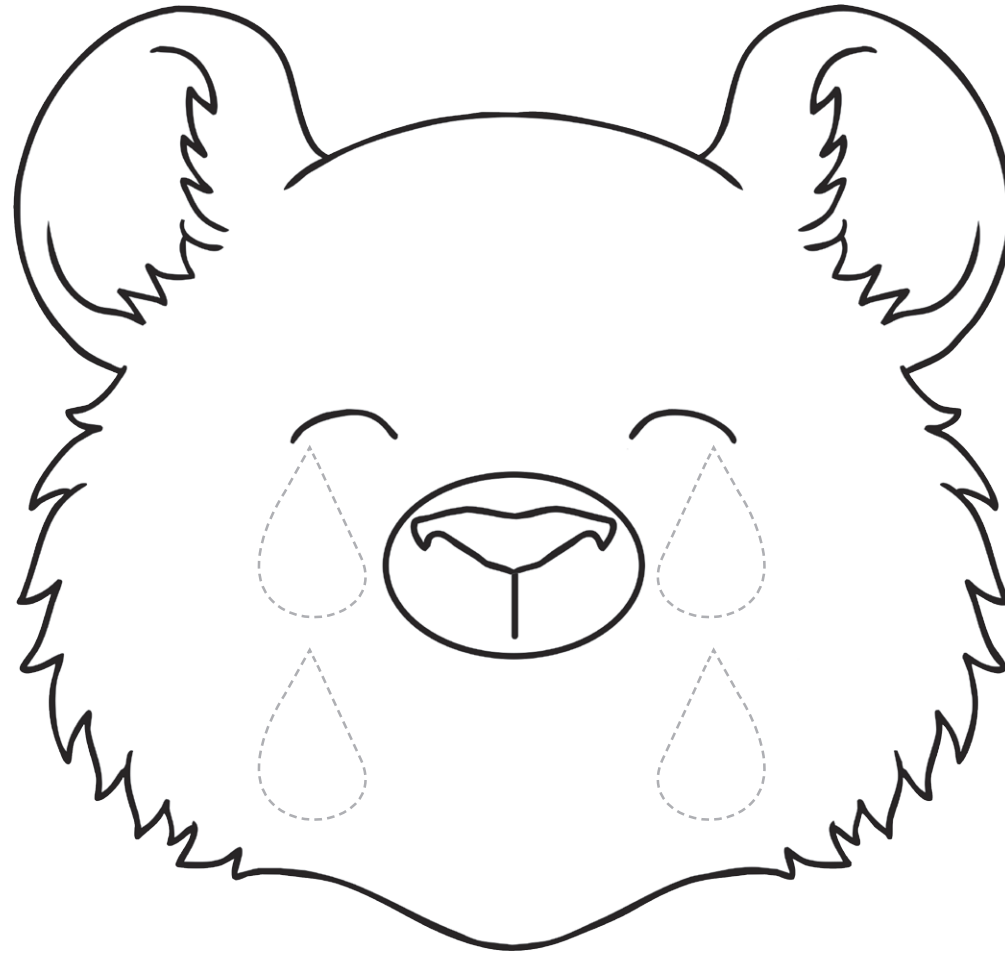

# Goldilocks and the Three Bears Fine Motor Skills Story

When they got to the bedroom, they saw that someone had been sleeping in their beds and she was still there!  
Just then, Goldilocks woke up and screamed, "Help!"

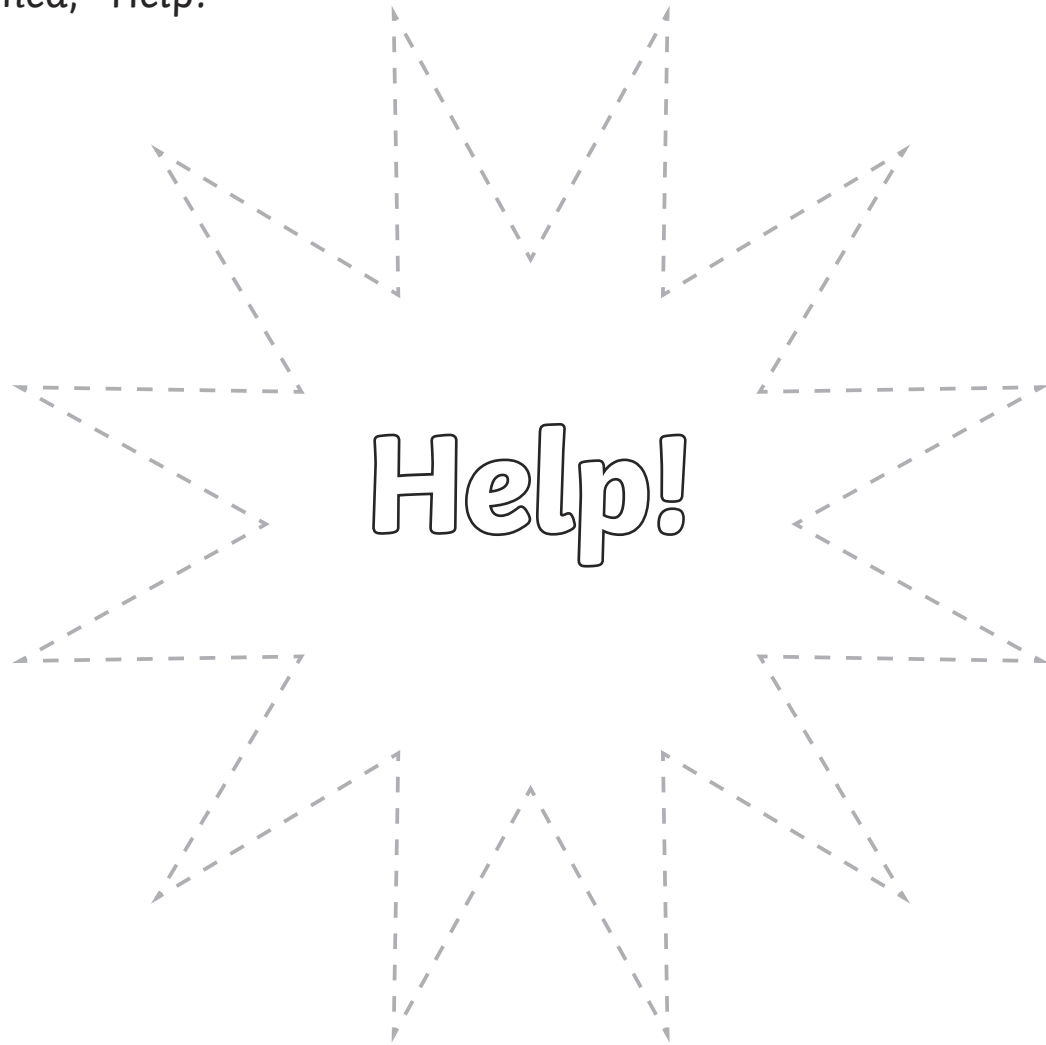

# Goldilocks and the Three Bears Fine Motor Skills Story

Goldilocks ran through the forest and she never went back into the woods again.

